



Real-Time Solar–Diesel Generator Power Coordination for Industrial Loads Under Grid Outage Conditions

K Sivasankar, S. Muthukrishnan



Abstract: *There is a growing interest from opinion-making bodies and the government to promote the use of solar photovoltaic (PV) systems in the industrial sector. But most grid-connected solar PV plants are equipped with anti-islanding protection that causes the solar inverter to disconnect immediately when the utility grid is down. While this protection helps ensure the safety of utility employees and equipment, it also means that solar energy cannot be used during outages. As such, the industry relies almost entirely on diesel generators (DGs) for power supply, even during the day when solar power is available. The SABIC Research and Technology Centre in Bangalore has a 540-kW grid-connected rooftop solar photovoltaic system. The site consumes about 2,160 kWh of electricity per day. The solar plant indeed makes a noticeable contribution to the load under normal conditions. However, the PV system shuts down during grid power outages due to anti-islanding protection, and the facility runs on DG power only, even though solar power is available. This bottleneck has cost the facility nearly 2.4 lakh kWh of potential solar energy generation over the last two years alone, leading to increased diesel use, higher operating expenses, and higher carbon emissions. This study presents a real-time solar–diesel generator coordination control strategy that enables high penetration and controlled use of solar power during grid outages. The proposed controller adaptively adjusts the output of the solar inverter based on the load demand, the diesel generator's operating limits, and the system voltage and frequency. It also prevents reverse power flow to the diesel generator and maintains a minimum spinning reserve for stable operation. The discussed system is simulated and modelled in MATLAB/Simulink. Simulation results demonstrate that different scenarios were analysed, including grid outage, load variation, and solar generation fluctuation. The simulation results show that the presented scheme can maintain stable system voltage and frequency and maximise solar power utilisation. The system significantly reduces the diesel generator load and fuel consumption, improving energy efficiency and environmental friendliness for the industrial plant.*

Keywords: Photovoltaic (PV) Solar Energy, Diesel Generator (DG), Grid Outage, Isolated Functioning, Control of Microgrid, Renewable Energy Integration, Real-Time Energy Management

Nomenclature:

DGs: Diesel Generators

VF: Voltage and Frequency

DOBC: Disturbance Observer-Based Control
EMS: Energy Management System

I. INTRODUCTION

A. Background

Industrial sectors are increasingly adopting renewable energy solutions to reduce their reliance on fossil fuels. Scalability and declining installation costs have made solar photovoltaic systems one of the most common renewable energy technologies.

Grid-tied rooftop solar systems are a favourite option—because the sun is free, solar farms and industrial plants tend to use power from the roof to cut energy costs. Solar PV systems produce electricity under normal operating conditions and supply local loads, while the grid supports system voltage and frequency stability.

But grid-connected solar inverters do have anti-islanding protection, which means the PV system will automatically disconnect when the grid supply is cut off. It is this safety device that prevents the utility grid from being inadvertently energised during a blackout. [Fig.1](#) shows the general layout of the grid-tied solar system.

Consequently, solar generation ceases during grid outages, even if the sun is shining. Then the entire industrial load has to be supplied by diesel generating sets. This means more fuel is burned, operating expenses are higher, and the potential for using renewable energy is reduced.

The SABIC Research and Technology Centre in Bangalore is a practical illustration of this problem. The plant has a 540-kW rooftop solar PV system connected to the utility grid. It is estimated that the facility consumes an average of 2,160 kWh per day. Under normal circumstances, the solar farm accounts for a large share of the demand. Yet this reliance on farm power proves ironic, as the solar PV system shuts down during grid outages due to anti-islanding protection, leaving the entire plant to rely on diesel generator power.

The operation information shows that nearly 2.4 lakh kWh of potential solar energy was wasted over the last two years due to solar shutdowns during grid failures. This led to higher diesel usage and increased running costs.

Manuscript received on 06 April 2026 | First Revised Manuscript received on 25 April 2026 | Second Revised Manuscript received on 08 May 2026 | Manuscript Accepted on 15 May 2026 | Manuscript published on 30 May 2026.

*Correspondence Author(s)

K Sivasankar*, Department of Electrical and Electronics Engineering, Adhiyamaan College of Engineering, Hosur (Tamil Nadu), India. Email ID: sivasankarprof@gmail.com, ORCID ID: [0009-0005-5980-6361](https://orcid.org/0009-0005-5980-6361)

Dr. S. Muthukrishnan, Professor, Department of Electrical and Electronics Engineering, Adhiyamaan College of Engineering, Hosur (Tamil Nadu), India. Email ID: mutudt04@gmail.com, ORCID ID: [0000-0002-8775-9866](https://orcid.org/0000-0002-8775-9866)

© The Authors. Published by Blue Eyes Intelligence Engineering and Sciences Publication (BEIESP). This is an open-access article under the CC-BY-NC-ND license <http://creativecommons.org/licenses/by-nc-nd/4.0/>

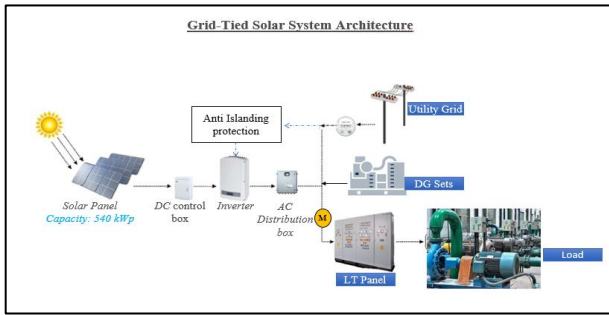

[Fig.1: Block Diagram of Grid-Tied Solar System Architecture]

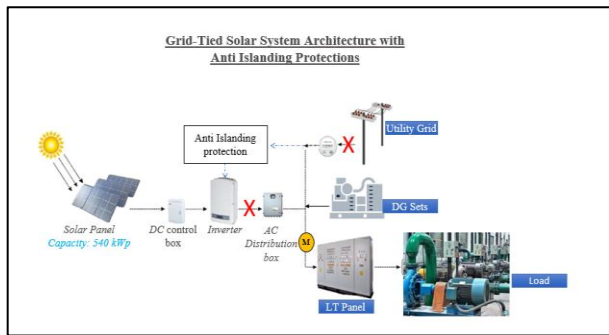

[Fig.2: Block Diagram of Grid-Tied Solar System Architecture with Anti-Islanding Protection]

The system with anti-islanding protection is illustrated in [Fig.2](#) and provides safety in the event of grid collapse.

To mitigate this problem, the industry is now exploring hybrid solar-diesel power systems that enable solar PV to be used in combination with diesel generators on the grid when the grid is down. In these applications, the diesel genset serves as the grid-forming source and provides the voltage and frequency references for the solar inverter.

But there are numerous technical problems to solve in making solar PV and a diesel generator work together. One of the big issues is preventing power from flowing back into the diesel generator when solar production exceeds demand. Power reversal can damage the generator and lead to system instability. The other challenge is for the system to maintain stable voltage and frequency (VF) in islanded mode.

This work presents a real-time solar–diesel generator coordination controller to overcome the above challenges. The controller adjusts solar power production in response to load demand and generator status, enabling controlled production while the grid is down. The system minimises diesel use while maximising renewable energy use in industry facilities.

B. Problem Identification

In this study, a 540–750 kW rooftop solar PV system is installed at the Sabic plant to meet daytime electricity demand. Nevertheless, the PV system stops operating upon grid failure due to the anti-islanding protection.

C. This Results in:

- Fully reliant on diesel generators
- Loss of potential generation of solar energy
- Fuel costs and operating costs increase
- Increased carbon emissions
- Reduced return for the solar plant

Studies have shown that 2.4 Lacs units of solar energy were lost over two years due to PV shutdown during grid outages.

D. Objectives

The contributions and novelties of this study are as follows:

- Investigate the operational constraints of grid-connected solar PV in the event of grid collapse.
- Development of a smart coordination scheme between solar PV and diesel generator.
- Allowing for a safe use of the sun during islanded operation.
- Stop reverse power from flowing back into the diesel generator.
- Ensure stable voltage and frequency during the absence of a grid.
- Through simulation to verify the proposed system.

II. LITERATURE REVIEW

Hybrid renewable energy systems, such as PV–diesel hybrid microgrids, are increasingly being considered an established solution due to their ability to enhance energy reliability, reduce fuel consumption, and increase renewable energy integration. These systems combine renewable energy with traditional diesel generators to provide continuous and stable power, primarily for remote or industrial use where grid reliability is poor.

Manandhar, Ukil, and Manandhar (2023) present an improved EMS for an isolated hybrid microgrid. The hybrid consists of a diesel generator, renewable energy, and energy storage [1]. The work was mainly focused on enhancing operational performance.

The EMS dynamically allocates power output between the renewable and diesel sources based on load and renewable availability. The results showed that the proposed approach achieves higher renewable energy penetration and lower diesel consumption and operating costs. The study emphasises that intelligent energy management techniques are vital for the high efficiency and sustainability of microgrids.

Wu and Yang (2023) studied the challenges to frequency stability in photovoltaic–diesel hybrid microgrids and introduced a dual-driven predictive control scheme for secondary frequency regulation [2]. Because of the intermittent nature of solar irradiance and the low inertia of inverter-based generation, microgrids are prone to frequency fluctuations under abrupt load changes. The predictive control approach presented enhances system stability by accelerating the dynamic response and attenuating frequency deviations. The simulation results showed a considerable enhancement in system performance following a load disturbance, suggesting that a predictive control technique can improve the reliability of the hybrid microgrid.

Grover, Verma, and Bhatti (2022) presented a disturbance observer-based control (DOBC) approach for voltage and frequency control in a PV–diesel hybrid microgrid operating in islanded mode [3]. An islanding event occurs when a microgrid operates independently of the main utility grid, making voltage and frequency control more difficult. The disturbances and the disturbance-related uncertainty are predicted in real time and compensated for via adaptive control actions in the DOBC

scheme. The study revealed that the presented technique can secure voltage and frequency restoration without a battery-based energy storage device. This work offers an inexpensive control approach to enhance the robustness and stability of islanded hybrid microgrids.

Hassan, Algburi, and Sameen (2023) reviewed hybrid renewable energy systems, including solar and wind solutions, with particular attention to PV–diesel hybrids [4]. This review also elaborated on various system designs, control strategies, and the associated problems of energy management in hybrid energy systems. The authors stated that hybrid systems greatly improve power supply reliability and significantly reduce greenhouse gas emissions. The review further identified the challenges of developing efficient optimisation techniques and advanced control schemes to enhance the penetration of renewable energy in hybrid power systems.

Gharib (2026) addressed the performance improvement of stand-alone PV–diesel generator systems through a techno-economic analysis [5]. The analysis considered variations in PV capacity, diesel generator sizing, load demand patterns, and fuel consumption. In this study, optimal system

configurations that minimise LCC with reliability consideration are determined using optimisation methods. The results revealed that optimising system size and running strategy can considerably reduce diesel generator running and fuel consumption.

Along the same lines, **Aslam, Bhatti, and Siddique (2025)** assessed the construction and operation of an islanded hybrid microgrid for industrial use [6]. Their findings showed that co-using solar PV with diesel generators can reduce fuel consumption, improve power quality, and increase renewable energy utilisation under industrial load fluctuations. The results demonstrate the feasibility of industrial applications of hybrid microgrids with a dependable power supply.

In general, the cited literature illustrates an increasing trend towards hybrid PV–diesel microgrids to provide reliable and sustainable energy systems. Sophisticated EMSs, predictive control methodologies, and optimisation-based techniques are necessary to enhance system performance, operational profit, and/or the penetration of renewable energy sources. Nevertheless, more studies are necessary to develop better control algorithms and integration strategies for large-scale industrial implementations.

Table I: Article Summary of Reviewed Literature

S. No	Author(s)	Year	Title / Journal	Key Findings / Contributions
1	U. Manandhar, A. Ukil, and K. B. Manandhar	2023	Enhanced energy management system for isolated microgrid with diesel generators, renewable generation, and energy storage – Applied Energy	An Energy Management System (EMS) for an isolated diesel generator hybrid microgrid with renewable energy was presented. Showed increased renewable satellite, lower diesel use, and better operational security via coordinated dispatch policies.
2	J. Wu & F. Yang	2023	A dual-driven predictive control for photovoltaic-diesel microgrid secondary frequency regulation – Applied Energy	A dual-driven predictive control strategy is developed for secondary frequency regulation in PV–diesel microgrids. Improved dynamic performance and mitigated the low-inertia problem, resulting in improved system stability under varying loads.
3	H. Grover, A. Verma, and T. S. Bhatti	2022	DOBC-based frequency & voltage regulation strategy for PV–diesel hybrid microgrid during islanding conditions – Renewable Energy	The stability of islanded PV–diesel microgrids is studied using a proposed disturbance observer-based control (DOBC) scheme that delivers superior voltage and frequency regulation without battery energy storage, thereby enhancing the microgrid's robustness to disturbances.
4	Q. Hassan, S. Algburi, and A. Z. Sameen	2023	A review of hybrid renewable energy systems: Solar and wind-powered solutions – Results in Engineering	Reviewed a wide range of hybrid renewable systems, such as PV–diesel systems. The issues of integration, control techniques, and reliability in hybrid power systems were discussed.
5	M. R. Gharib	2026	Optimizing stand-alone hybrid PV/Diesel Generator system – Energy Conversion and Management	Studies on the optimisation of standalone PV–diesel hybrid systems are conducted to consider cost, reliability, and operational effectiveness. Provided techno-economic evaluation for optimal system sizing and dispatch
6	W. Aslam, M. Z. Asif Bhatti, and Abubakar Siddique	2025	Design and performance evaluation of an islanded hybrid microgrid for an industrial warehouse – Energy Conversion and Management	Assessed the design and running effectiveness of the islanded PV–diesel hybrid microgrid in an industrial area. Demonstrated fuel savings, power quality improvement, and increased renewable utilisation at different industrial loads.

Table I: Provides a structured summary of key research papers, including author details, methodology, and major findings, to help understand the current state of research.

A. Research Gap and Opportunity

In this paper, we review prior research on hybrid photovoltaic (PV)–diesel microgrid systems aimed at enhancing energy reliability and renewable energy penetration. However, they face certain limitations in applicability, especially in industrial settings. Manandhar has proposed an advanced Energy Management System (EMS) for off-grid microgrids that uses battery energy storage systems to manage the intermittency of renewable energy. This adds cost and complexity to the system [1] and does not

consider retrofit solutions for grid-connected industrial PV systems without storage. Hence, it is possible to establish a battery-less real-time coordination strategy for an industrial rooftop PV system coupled with a diesel generator during a grid outage.

In addition, **Wu and Yang (2023)** presented a model predictive control scheme for frequency balancing in PV–diesel MGs. Nevertheless, the approach is complicated to realise, and the two sides of industrial load volatility [2] and the effect of reverse power-flow protection is not fully taken into consideration. In this paper, **Grover (2022)** focuses on disturbance observer-based



control of islanded microgrids. Yet, the proposed approach is primarily validated through simulation, and anti-islanding protection in grid-connected PV systems is not considered [3].

Additionally, Hassan (2023) presents a generalised review of hybrid renewable systems, but without the attestation of

control solutions for specific applications. Gharib (2026) focused on system optimisation rather than real-time operational coordination [5]. Therefore, this work proposes a practical real-time control strategy [6] for industrial PV–diesel systems under grid failures to improve solar utilisation with minimal investment in new infrastructure.

Table II: Detailed Literature Gaps and Research Opportunities

S. No	Author(s)	Year	Project Title / Journal	Identified Gap in Existing Work	Research Opportunity in Present Work
1	U. Manandhar, A. Ukil, and K. B. Manandhar	2023	Enhanced energy management system for isolated microgrid with diesel generators, renewable generation, and energy storage – Applied Energy	The EMS architecture is designed specifically for stand-alone microgrids with ESS. This protocol presupposes the use of batteries to smooth out the intermittency of renewable energy, thereby increasing the system's cost and complexity. There's less talk on retrofitting in existing industrial grid-tied PV systems that have no storage.	Development of a battery-free real-time coordination method for a set of industrial rooftop PV systems connected to diesel generators in the scenario of grid outages.
2	J. Wu & F. Yang	2023	A dual-driven predictive control for photovoltaic-diesel microgrid secondary frequency regulation – Applied Energy	Concentrates mainly on predictive secondary frequency control for microgrids. The variability of industrial loads and the prevention of reverse power flow are not fully addressed—predictive control complexity may restrain practical implementation in industry.	In this paper, a simpler measurement-based decentralised control method is proposed to achieve stable frequency regulation and to manage industrial load changes and distributed generation (DG) protection limitations.
3	H. Grover, A. Verma, and T. S. Bhatti	2022	DOBC-based frequency & voltage regulation strategy for PV–diesel hybrid microgrid during islanding conditions – Renewable Energy	Validation of the DOBC scheme is primarily conducted through simulation of the microgrid system. Commercial grid-connected PV systems with anti-islanding restrictions are not considered.	Design and implement anti-islanding functionality with centralised DG control to meet protection standards and maximise solar usage.
4	Q. Hassan, S. Algburi, and A. Z. Sameen	2023	A review of hybrid renewable energy systems: Solar and wind-powered solutions – Results in Engineering	Outlines an extensive but general overview, without real-time control strategies, for coordinating the PV–diesel system during grid outages. The aim is theoretical and system-level.	Provide an application-specific real-time coordination framework tailored for industrial solar-DG systems operating during utility outages.
5	M. R. Gharib	2026	Optimizing stand-alone hybrid PV/Diesel Generator system – Energy Conversion and Management	Focuses on the planning and sizing of standalone systems, rather than on running coordination during transient operation during grid-off events.	Develop an application-oriented, real-time coordination scheme for an industrial solar-DG system operating in the grid during utility interruptions.
6	W. Aslam, M. Z. Asif Bhatti, and Abubakar Siddique	2025	Design and performance evaluation of an islanded hybrid microgrid for an industrial warehouse – Energy Conversion and Management	Design study for a specific case; no general coordination algorithm for different industrial load types is provided.	Develop generic control logic applicable to many plants with minimal changes.

Table II: Presents a critical analysis of literature gaps and outlines future research directions to improve PV–DG coordination systems.

III. METHODOLOGY

The methodology consists of four main stages.

1. System Modelling
2. Control Algorithm Development
3. Simulation Setup
4. Performance Analysis

A. System Modelling

The presented HVDC system model with a hybrid power source comprises six main components. Fig. 3: The whole hybrid system (PV array, inverter, DG and industrial load)

1. Solar PV Array,
2. Solar Inverter,
3. Diesel Generator (DG),
4. Industrial Load,

5. Grid Supply
6. An Intelligent Controller.

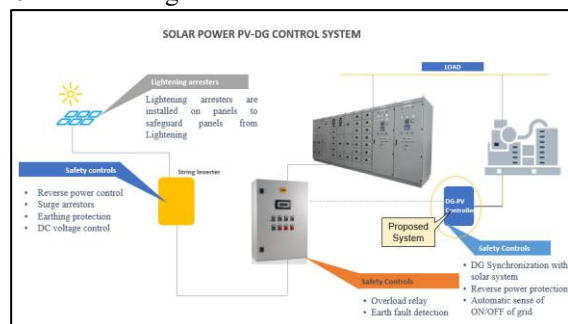

[Fig.3: Solar Power PV–DG Control System Schematic Diagram]

The Solar PV array converts solar irradiation is converted into electrical power, which is then converted to AC power



by the solar inverter. Under normal operating conditions, the industrial load is primarily supplied by the grid and solar PV generation. The diesel generator serves as a backup power source to maintain power in the event of a grid failure.

A key part of this is the smart controller that manages the operation of the PV system and the diesel generator. It monitors system parameters, including solar generation, load demand, and generator output, in real time to ensure steady operation. The controller also has to protect against reverse power flow from the solar PV system to the diesel generator, which can cause protection trips and operational instabilities.

The power balance in the system is maintained based on the following relationship:

$$P_{Load} = P_{Solar} + P_{DG}$$

Where

P_{load} = Total load demand

P_{solar} = Solar PV power output

P_{DG} = Diesel generator power output

To prevent reverse power flow, the solar power output must satisfy:

$$P_{Solar} \leq P_{Load} - P_{margin}$$

where P_{margin} is a safety margin to keep the diesel generator with enough spinning reserve to accommodate rate load change and to keep stable system operation.

B. Control Logic

The Core is a central element in the suggested PV–Diesel hybrid system. It significantly helps track power system operating conditions and manage the joint operation of the solar photovoltaic system, the diesel generator, the grid supply, and the industrial load. With real-time measurement and decision making, the controller guarantees a reliable power supply and avoids system problems like reverse power flow and system instability, see Fig.4: Describes the controller for power sharing PV and DG.

C. System Inputs

The controller is subjected to multiple real-time inputs, different from various modules of the system:

- 1. Grid Status:** whether the utility grid is present or absent with a power outage.
- 2. Load Demand:** Does the industrial plant consume the aggregate active electrical power?
- 3. Solar Power Output:** Monitors the current power generated by the solar PV plant.
- 4. Voltage at Point of Common Coupling (PCC):** Keeps the voltage within allowable operating limits.
- 5. Frequency at PCC:** Tracks system frequency for stable operation during islanding.

With these inputs, the controller can make informed decisions about system operation.

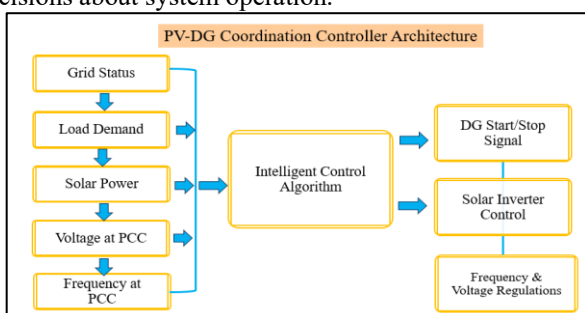

[Fig.4: PV-DG Coordination Controller Architecture]

D. Control Algorithm

The governing algorithm runs in an infinite while loop to properly coordinate the system's components.

Step 1: Grid Status Detection

The controller first confirms the availability of the grid supply. When the grid is available, the system operates in standard grid-connected mode.

Step 2: Normal Solar Operation

When the grid is on, the output of solar PV contributes to the load, and the load borrows from the grid to make up for the solar PV generation.

Step 3: Grid Failure Detection

If a grid failure occurs, the controller immediately starts the diesel generator sequence to maintain power to critical industrial loads.

Step 4: Load Measurement

After the diesel generator is stabilised, the controller measures the real-time load demand.

Step 5: Solar Power Calculation

The controller calculates the allowable solar power limit based on load demand and the minimum operating capacity required for the diesel generator.

Step 6: Solar Inverter Output Limitation

The controller limits the output of the solar inverter so that solar production does not exceed the allowable limit, preventing power flow from the solar inverter to the diesel generator.

Step 7: Voltage and Frequency Monitoring

The controller continuously monitors the PCC voltage and frequency to ensure stable system operation.

Step 8: Reverse Power Flow Prevention

Control actions are implemented to balance between solar, diesel, and load.

Step 9: Continuous Control Update

The control signals are constantly revised by the controller to adapt to variations in solar generation and industrial load, ensuring safe, dependable, and high-quality system operation.

E. Simulation Setup

i. System Simulation and Scenarios

In this paper, a PV–Diesel hybrid system is studied using the MATLAB/Simulink simulation tool, which provides a suitable environment for analysing the power system's performance under varying operating conditions. The developed simulation model accurately depicts the dynamics of the major components of the hybrid system and enables evaluation of the system's stability, power, and control.

ii. Simulation Components

The simulation model comprises several major components that represent the real-time operation of the hybrid power system.

F. PV Array Model

The photovoltaic (PV) panel model calculates solar power production as a function of solar intensity and temperature. It is known as a DC power producer; the output power depends on the environmental conditions.

Fig.5: Depicts the electrical model of the solar PV array



used in simulation, and Fig.6: Illustrates the solar model in the Matlab Simulink program

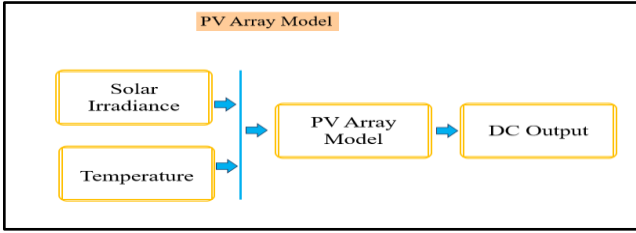

[Fig.5: PV Array Model]

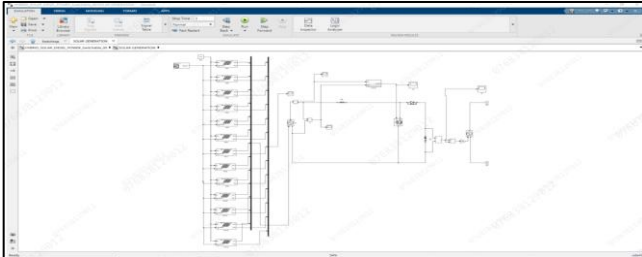

[Fig.6: MATLAB Solar Model]

G. Solar Inverter Model

The solar inverter converts the DC electricity generated by the PV array into AC electricity that industrial loads can use. The inverter model also incorporates power-control techniques to limit solar production during grid outages to prevent reverse power flow; see Fig.7, which depicts the inverter control policy for regulating voltage and frequency.

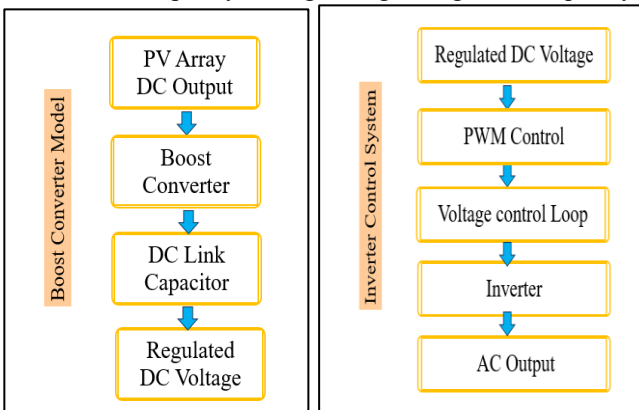

[Fig.7: Solar Inverter Model]

H. Diesel Generator Model:

The diesel generator (DG) model is the backup power source during a grid failure. It models generator dynamics, governor control, and voltage regulation to achieve stable frequency and voltage when operating in island mode, as shown in Fig.8: The diesel generator dynamics and control system. Fig.8: Diesel generator dynamics and control system. Fig.9: Represents the diesel generator dynamics and control system in MATLAB.

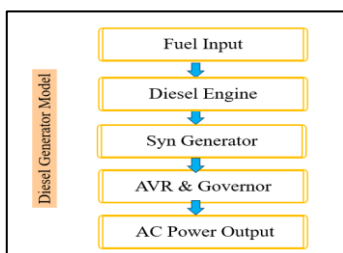

[Fig.8: Diesel Generator Model]

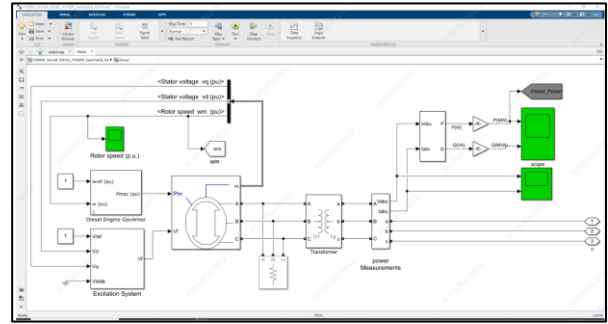

[Fig.9: Diesel Generator Model in Matlab]

I. Industrial Load Model

Industry loads are defined by facility demand. It incorporates a set of load-profile features to mimic realistic fluctuations in an industry's load.

J. Control System

The intelligent controller manages the PV system and the diesel generator. It tracks grid condition, load requirements, solar production, and system parameters to ensure stable operation. Fig.10: Decision-making logic for PV- DG start/stop and load management. Fig.11: Decision-making logic for PV-DG start/stop and load management in Matlab, and Fig.12: Internal sequential logic for PV-DG start/stop and load management in Matlab.

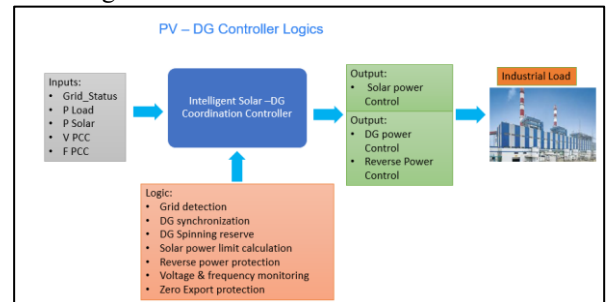

[Fig.10: PV–DG Controller Logic]

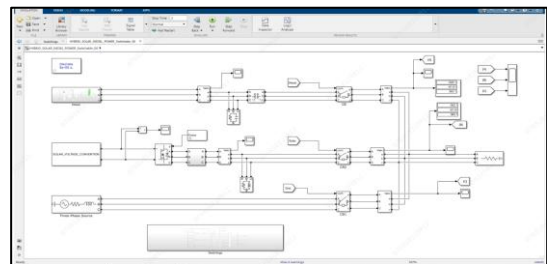

[Fig.11: PV–DG Controller Simulation Logic in Matlab]

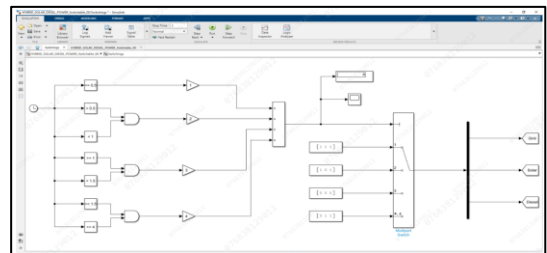

[Fig.12: PV–DG Controller Simulation Internal Sequential Logic in Matlab]

i. Simulation Scenarios

Three main simulation scenarios are considered to





assess the system's performance.

- **Normal Grid Operation:** Solar PV provides a share of the load, with the grid catering for the rest.
- **Grid Failure with DG Only:** When solar production is not available, the diesel generator provides for the whole load.
- **Grid Failure with Coordinated PV-DG Operation:** The PV and DG function in a coordinated manner under the supervision of the controller, so maximum solar utilisation is ensured with no reverse power flow, and system stability is ensured.

IV. RESULTS AND DISCUSSION

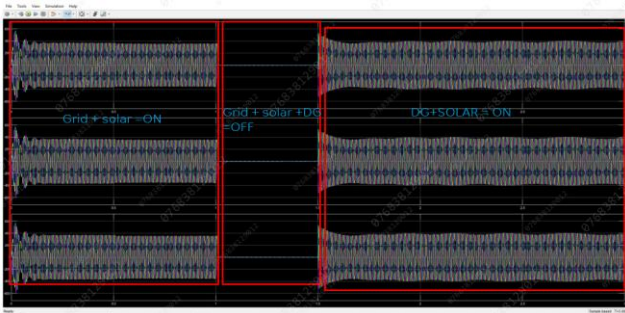

[Fig.13: PV-DG Controller Simulation Output]

The simulation results indicate that the proposed solar-diesel coordination controller effectively enhances the system's performance under grid-failure conditions. Fig. 13: PV-DG Controller Simulation Results. In the traditional system, the solar PV plant immediately powers off when the grid is down due to anti-islanding protection. Consequently, the load is met entirely by the diesel generator, resulting in higher fuel consumption and running costs.

During grid outages, the solar PV system can operate using the proposed coordination controller, while the diesel gen-set serves as the voltage and frequency reference. The controller dynamically adjusts the solar power output to ensure that the rotating diesel generator has adequate spinning reserve.

Simulation results demonstrate a substantial decrease in diesel generator load with the availability of solar power. The decrease in generator loading results in lower fuel consumption and improved generator efficiency.

The voltage and frequency patterns recorded during the simulation are also within the tolerable range, indicating that the system is stable. In addition, the controller effectively prevents any reverse power flow to the diesel generator, even when solar generation approaches the load demand (Fig.9). Overall, simulation results verify that the proposed PV-DG coordination strategy can better utilise solar energy during grid outages while maintaining a reliable supply to industrial loads.

V. CONCLUSION

This report focused on the associated problems with using solar PV systems at industrial sites during grid outages. In a normal grid-tied solar PV system, the solar inverter will also shut down due to anti-islanding protection when the grid goes down. Therefore, the industries are to rely wholly on diesel generators in the event of a power cut; not even solar energy can be tapped.

An illustration of the problem is at SABIC Research and Technology Centre in Bangalore, where a 540-kW rooftop solar plant idles during grid outages, resulting in significant loss of solar energy generation.

To this end, a real-time solar-diesel coordination controller is developed in this work. The controller also enables the use of solar power during grid outages by adjusting the solar inverter output to match load demand and the diesel generator operating limits.

Simulation results based on MATLAB/Simulink have shown that the proposed system can operate with stable voltage and frequency in islanded mode. Reverse power flow to the diesel generator is prevented, and the controller maintains sufficient spinning reserve.

The results show that the proposed scheduling approach can achieve a substantial reduction in diesel fuel consumption and enhance the penetration of renewables in industrial plants.

FUTURE WORK

Future work can build on this study by applying more advanced control methodologies (such as artificial intelligence and machine learning) to optimise solar-diesel coordination. Integration of battery energy storage systems (BESSs) can also be considered to enhance flexibility and improve dynamic responses under rapidly varying solar generation.

Besides, it is interesting to investigate the design of a hardware prototype and the real-time implementation of the proposed controller based on a PLC- or microcontroller-supported platform. Field tests of the controller in a real plant would be of interest and would inform runtime behaviour and implementation issues.

Additional investigations can explore integrating diverse renewable energy sources, including wind power, with energy storage to form an entirely self-sustained industrial microgrid that can operate in off-grid mode.

DECLARATION STATEMENT

As the article's author, I must verify the accuracy of the following information after aggregating input from all authors.

- **Conflicts of Interest/ Competing Interests:** Based on my understanding, this article has no conflicts of interest.
- **Funding Support:** This article has not been funded by any organisations or agencies. This independence ensures that the research is conducted objectively and without external influence.
- **Ethical Approval and Consent to Participate:** The content of this article does not necessitate ethical approval or consent to participate with supporting documentation.
- **Data Access Statement and Material Availability:** The adequate resources of this article are publicly accessible.
- **Author's Contributions:** The authorship of this article is contributed equally to all participating individuals.



REFERENCES

1. U. Manandhar, A. Ukil, and K. B. Manandhar, “Enhanced energy management system for isolated microgrid with diesel generators, renewable generation, and energy storage,” *Applied Energy*, vol. 350, 2023, Art. no. 121624.
DOI: <https://doi.org/10.1016/j.apenergy.2023.121624>
2. J. Wu and F. Yang, “A dual-driven predictive control for photovoltaic–diesel microgrid secondary frequency regulation,” *Applied Energy*, vol. 334, 2023, Art. no. 120652.
DOI: <https://doi.org/10.1016/j.apenergy.2023.120652>
3. H. Grover, A. Verma, and T. S. Bhatti, “DOBC-based frequency and voltage regulation strategy for PV–diesel hybrid microgrid during islanding conditions,” *Renewable Energy*, vol. 196, pp. 883–900, 2022.
DOI: <https://doi.org/10.1016/j.renene.2022.06.140>
4. Q. Hassan, S. Algburi, and A. Z. Sameen, “A review of hybrid renewable energy systems: Solar and wind-powered solutions,” *Results in Engineering*, vol. 20, 2023, Art. no. 101621.
DOI: <https://doi.org/10.1016/j.rineng.2023.101621>
5. M. R. Gharib, “Optimizing stand-alone hybrid PV/Diesel Generator system,” *Energy Conversion and Management*, vol. 30, 2026, Art. no. 101562. DOI: <https://doi.org/10.1016/j.ecmx.2026.101562>
6. W. Aslam, M. Z. Asif Bhatti, and Abubakar Siddique, “Design and performance evaluation of an islanded hybrid microgrid for an industrial warehouse,” *Result in Engineering*, vol. 28, 2025, Art. no. 107494.
DOI: <https://doi.org/10.1016/j.rineng.2025.107494>

AUTHOR’S PROFILE



K. Sivasankar is currently pursuing his Master of Engineering (M.E.) in Power Systems (2025–2026) at Adhiyamaan College of Engineering, Hosur, Tamil Nadu, India. His academic interests include power system optimization, energy efficiency, renewable integration, and industrial energy management. He is actively involved in research related to electrical energy conservation and sustainable energy practices. He has presented and contributed to academic projects focused on energy auditing and system performance improvement in industrial facilities.



Dr. S. Muthukrishnan is a Professor in the Department of Electrical and Electronics Engineering at Adhiyamaan College of Engineering, Hosur, Tamil Nadu, India. He has extensive teaching and research experience in power systems, energy management, and control systems. His areas of expertise include electrical system design, energy conservation, and power quality improvement. He has guided numerous postgraduate and undergraduate projects and has published several papers in reputable national journals.

Disclaimer/Publisher’s Note: The statements, opinions and data contained in all publications are solely those of the individual author(s) and contributor(s) and not of the Blue Eyes Intelligence Engineering and Sciences Publication (BEIESP)/ journal and/or the editor(s). The Blue Eyes Intelligence Engineering and Sciences Publication (BEIESP) and/or the editor(s) disclaim responsibility for any injury to people or property resulting from any ideas, methods, instructions or products referred to in the content.