

# A Review on Maximum Power Point Tracking (MPPT) Controlling Methods for A Photovoltaic System

Pawan D. Kale, D. S. Chaudhari

**Abstract**— A renewable energy had been used in solar power generation since years ago. Solar energy is one of the forms of renewable energy source and it brings benefits to the residential that uses it as their alternative power supply. In order to increase the efficiency of system during rapid changing environmental conditions; system will adapt some Maximum Power Point Tracking (MPPT) methods. This paper presents a review on various MPPT methods for variable environmental conditions (i.e. variable temperature and irradiation level), their difficulty while tracking and how those difficulties can be overcome efficiently by the other techniques. Apart from all the methods, an open circuit and slope detection tracking technique is found to be an efficient technique with respect to tracking speed and accuracy. This technique can avoid the unnecessary amount of power loss and therefore maintaining the power efficiency. The Programmable system on chip (PSoC) is used as a Maximum Power Point Tracking (MPPT) controller.

**Keywords**—MPP (Maximum Power Point), MPPT (Maximum Power Point Tracking), PSoC (Programmable System on Chip), PV (Photovoltaic) panel.

## I. INTRODUCTION

In these modern days that consume a lot of energy e.g. fuel-oil, gas, coal etc. that will deplete in its source one day so, much of the focus have been given on the topic of renewable energy. Renewable energies are energy that can be renewed or have no worries of depletion. For instance wind, thermal, bio-mass and solar energy are some of the examples for renewable energy [1]. Solar energy is one of the main renewable energy sources that are widely used in power generating application. Solar energy is an unlimited resource available in nature and set to become important in longer terms for providing heat energy and electricity to the user. This kind of energy resources does not create much pollution as the conventional power sources moreover it has the potential to be the major energy supply in future [1, 8]. In the last decade, there was a consistent development in the worldwide market of photovoltaic (PV) system. By the end of 2008, 13 GW of energy had been generated by the installed PV systems throughout the world. Out of the total system installed 6% were standalone systems, 33% were grid-connected centralized systems, and 61% were grid-connected distributed system. In 2008 alone, photovoltaic systems which generate up to 5.56 GW energy were installed. This represents the growth in PV systems increased by 1.5 times as compared with the previous year [2].

**Manuscript received on March 2013.**

**Pawan D. Kale**, Department of Electronics and Telecommunication, Government College of Engineering, Amravati, India.

**Dr. Devendra S. Chaudhari**, Department of Electronics and Telecommunication, Government College of Engineering, Amravati, India.

Solar panels have a nonlinear voltage current (V-I) characteristic with a distinct maximum power point (MPP), which depends on the environmental factors such as temperature and irradiation. In order to continuously harvest maximum power from the solar panels, it is necessary to control optimal impedance between the storage device and PV cell, so that the system can be operated at their Maximum power point (MPP), despite the inevitable changes in the environment. One useful impedance control method is called Maximum Power Point Tracking (MPPT) [3]. The MPPT control is a real time detecting panel output power and adapting the control algorithm to make the system operate under the optimum work state. MPPT control impedance to track the maximum power point by sensing the current and voltage from the PV cell. Now in order to sense current and voltage from panel, MPPT requires additional analog circuits moreover a high speed energy storage device is needed which can accumulate the acquirable maximum power and which changes according to the climate conditions. This requirement can be fulfilled by Programmable system on chip (PSoC) microcontroller, which reduces the need of separate analog circuits and act as an intelligent MPPT controller [3]. Lead acid battery is used as a quick charging energy storage device. A flexible MPPT controlling is produced for solar energy charging systems by using the combination of PSoC microcontroller and Lead acid battery.

## II. REVIEW OF MPPT METHODS

Researchers had found that the efficiency of the PV system can be increased by improving the conversion efficiency of solar cell i.e. an improvement of the solar cell material but this single factor is not enough to get the maximum power at load (Battery), so they developed some maximum power tracking algorithm, where much of the focus has been given on the improvement of power efficiency of the system.

### A. Perturb and Observe (P&O) algorithm

The Perturb and Observe is one of the so called 'hill climbing' MPPT methods which were developed by F. Iov *et al.* This method is based on the fact that, on the power voltage (P-V) characteristic curve, at the left of MPP the rate of change of power with respect to voltage is greater than zero i.e.  $dP/dV > 0$  while at the right, variation becomes less than zero i.e.  $dP/dV < 0$ . Fig.1 shows the power voltage (P-V) characteristic curve of Perturb and Observe (P&O) algorithm. As shown in figure, when the operating voltage of the PV panel is perturbed in a given direction and  $dP/dV > 0$ ; it is known that the perturbation moved the panel's operating point toward the MPP. The P&O algorithm would then continue to perturb the PV panel voltage in the same direction. If  $dP/dV < 0$  then the change in operating point



moved the PV panel away from the MPP and the P&O algorithm reverses the direction of the perturbation. [4, 5]

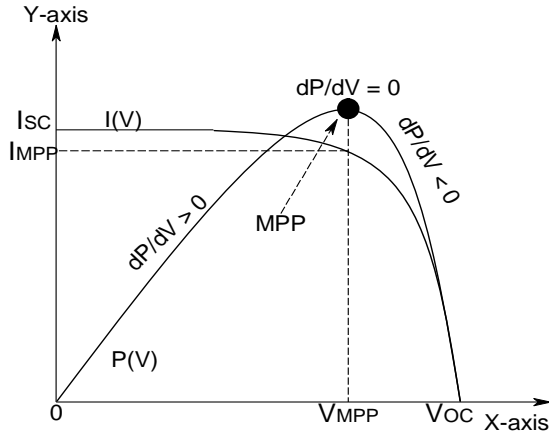

Fig.1. Sign of  $dP/dV$  at different position on the power-voltage characteristic of a PV cell. [4, 6]

### B. Incremental Conductance (INC) algorithm

A similar hill climbing MPPT algorithm is the Incremental Conductance (INC) which was developed by Rosa A. Mastromauro *et al.* This method intends to improve the P&O by replacing the derivative of the power versus voltage  $dP/dV$  used by the P&O with the PV panel instantaneous conductance ( $I/V$ ) and incremental ( $dI/dV$ ) conductance, according to (1) and (2).

$$\frac{dP}{dV_{pv}} = \frac{d(V_{pv} I_{pv})}{dV_{pv}} = I_{pv} + V_{pv} \frac{dI_{pv}}{dV_{pv}} \quad (1)$$

$$\left(\frac{1}{V_{pv}}\right) \frac{dP}{dV_{pv}} = \frac{I_{pv}}{V_{pv}} + \frac{dI_{pv}}{dV_{pv}} = G + dG \quad (2)$$

Where  $G$  is the conductance of PV cell and  $dG$  is the incremental conductance PV cell. The main objective of this method is to find the distance of PV operating point from the Maximum Power Point and can determine when the MPP has been reached and hence stop the perturbation. At maximum power point, the variation of power with operating point voltage of PV cell becomes zero i.e.  $\left(\frac{dP}{dV_{pv}} = 0\right)$  and therefore

from (2), the incremental conductance becomes  $\frac{dI_{pv}}{dV_{pv}} = -\frac{I_{pv}}{V_{pv}}$  and then the algorithm stops to perturb the

operating point. When operating point is varied, the method determines in which direction it must perturb the system depending upon the sign of  $\frac{dI_{pv}}{dV_{pv}}$ . This results in a

relationship between PV conductance and incremental conductance. [5, 6, 9]

### C. Modified INC algorithm

It is one of the MPPT methods, which was developed by Rosa A. Mastromauro *et al.* whose major approach was to improve the PV panel current rather than its voltage. The output of this method, result a current instead of the reference voltage where operating point is adjusted according to solar panel current. From the power voltage characteristic of PV cell, it is cleared that the variation in panel voltage becomes very slow at right side of the MPP and therefore it is considered to be constant, so between two sampling instance the voltage variation is negligible. As shown in fig.1, the variation in power with PV

panel voltage against PV current  $\frac{dP_{pv}}{dV_{pv}}$  provided almost a

linear relationship as compare to its variation against voltage.

As the variation  $\frac{dP_{pv}}{dV_{pv}}$  is linear, so reference current  $I_{ref}$  can

be easy to compute which is advantageous over calculation of reference voltage  $V_{ref}$  that could have a nonlinear relationship with  $\frac{dP_{pv}}{dV_{pv}}$ . For change in atmospheric condition

there is a variation in PV current i.e.  $dI_{pv} \neq 0$ , if such a condition occurs then check whether  $dI_{pv} < 0$ , if this condition is satisfied then variation in power with PV panel

voltage i.e.  $\frac{dP_{pv}}{dV_{pv}}$  is less than zero and reference current must

be increased so that operating point move towards MPP.

When variation in the PV current i.e.  $dI_{pv} > 0$  then  $\frac{dP_{pv}}{dV_{pv}} >$

0, and reference current must decreased so that operating point move towards MPP. [6]

### D. Constant Voltage (CV) algorithm

In order to track the maximum power from PV cell, MPPT controlling uses a Constant Voltage (CV) method. This method was described by Ryoustake Namba *et al.* in which maximum power point of the PV panel voltage changes slightly with irradiation. In order to allow the measurement of the open circuit voltage, MPPT momentarily sets the PV panel current to zero. The operating voltage is set to a fixed percentage of the open circuit voltage. The ratio between the open circuit voltage and MPP voltage depends on the solar panel parameters which having a value of 0.76 for commonly used crystalline silicone panel [5, 6]. The overall procedure of this method is divided in to three steps. Firstly the PV panel is disconnected from the battery and measure the open circuit voltage  $V_{oc}$ . From the measured voltage  $V_{oc}$  calculate the maximum power point voltage  $V_{MPP}$  by using following relation;

$$V_{MPP} = K \cdot V_{oc}$$

Where  $K=0.76$  is the proportionality constant.

Now in second stage, the PV panel output voltage  $V_{pv}$  can be finding out by connecting it with the battery. Lastly the optimal voltage  $V_{pv}$  can be controlled by minimizing the error between  $V_{MPP}$  and  $V_{pv}$ . For that pulse width modulation (PWM) technique is used to change the duty cycle ratio such that  $V_{pv}$  equals to  $V_{MPP}$ . [3]

### E. dP-P&O algorithm

The limitation of the hill climbing algorithm under rapidly changing irradiation is addressed and a simple improvement is proposed called the dP-P&O method which was developed by Dezso Sera *et al.* This method performs an additional measurement of power in the middle of the MPPT



sampling period (T) without any perturbation.

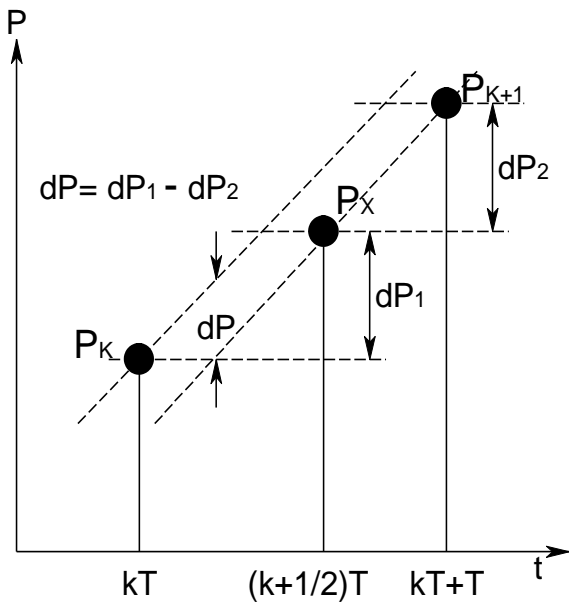

**Fig.2. Measurement of the power between two MPPT sampling instances. [7]**

As shown in Fig.2,  $P_K$  and  $P_{K+1}$  are the powers measured at the  $k$  and the  $k+1$  sampling instances,  $dP_1$  is the change in power caused by the perturbation of the MPPT and  $dP_2$  be the change in power caused by the increase in irradiation. The change in environmental condition can be shown by change of power between  $P_X$  and  $P_{K+1}$  reflects as no action has been taken by the MPPT. The changes in environmental condition with slight perturbation of the MPPT will results the change in power  $dP_1$  i.e. power difference between  $P_X$  and  $P_K$ . So assuming that over one sampling period of the MPPT the rate of change in the irradiation is constant, the  $dP$  caused purely by the MPPT command can be calculated as [4, 7];

$$\begin{aligned} dP &= dP_1 - dP_2 \\ &= (P_X - P_K) - (P_{K+1} - P_X) \\ &= 2P_X - P_{K+1} - P_K \end{aligned}$$

The resulting  $dP$  reflects the changes due to the perturbation of the MPPT method.

#### F. Open circuit and slope detection tracking algorithm

This algorithm was developed by Chih-Yu Yang *et al.* which overcomes the drawback of constant voltage algorithm. In this method, solar panel is disconnected from the power stage only at single time i.e. at the beginning of system power ON period.

The tracking procedure is divided into three steps, first step involve enabling open circuit tracking to measure open circuit voltage  $V_{oc}$  from which PV panel voltage can be calculated by setting it to  $0.7 \times V_{oc}$ . During open circuit voltage detection period, duty cycle of the boost converter is set to maximum value to increase tracking speed. In second stage slope detection tracking get activated to continuously and accurately track MPP which ensuring that the maximum amount of energy receives at power stage from solar panel. The last stage is for change in environmental condition such that when there was reduction in irradiation level then it means that slope changes from high to low. In such a condition, to increase the total amount of power, slope detection tracking technique increases the switching duty cycle so that PV panel current increases even though operating voltage is reduced. When the irradiation level are increased above the reference value i.e. for an increment in the PV panel operating voltage, then the slope detection tracking decreases the switching duty cycle so that PV panel current get decreased and optimal power produced at the power stage. [1]

A variable step perturbation technique (VSP) is used after the slope detection tracking technique to accelerate tracking speed and minimizing oscillation problem. It is based on the fact that, when the operating point is far away from the MPP then the system sets larger perturbation step size which increases the tracking speed, while for the operating point closer to MPP, system were chooses smaller step size in order to minimize oscillation around MPP. [1]

### III. VARIOUS MPPT METHODS

The motivation behind developing the various maximum power point tracking techniques was to increase the efficiency of the PV system at power stage i.e. an improvement in power efficiency. By considering this factor, different MPPT methods were proposed by the researchers. Each method is having their own features but some of them faces difficulties while tracking during rapidly change in the environmental condition. The classification of various MPPT methods is summarized in the following table.

**Table 1: Features of various MPPT method**

Sr. No.	MPPT Algorithm	Features
1	Perturb and Observe (P & O)	<ul style="list-style-type: none"> <li>• Easy to implement and having low computational demand.</li> <li>• Applicable for most of the systems.</li> <li>• Doesn't require any information about the PV panel, but only the measured voltage and current.</li> </ul>

2	Incremental Conductance (INC)	<ul style="list-style-type: none"> <li>Tracking maximum power point without oscillations around the MPP in steady state condition.</li> <li>Maximum tracking accuracy and faster speed.</li> </ul>
3	Modified INC	<ul style="list-style-type: none"> <li>The main approach is to use a linear relationship between PV current and variation in the PV panel output power with voltage instead of a nonlinear relationship between photovoltaic voltage and variation in the PV panel output power with voltage, so reference current is very easy to calculate than the reference voltage.</li> </ul>
4	Constant Voltage (CV)	<ul style="list-style-type: none"> <li>Rapidly detect the current maximum power point by measuring the open circuit voltage with periodically disconnecting the solar panel from power stage and directly multiplying it with a factor of <math>K=0.7</math>.</li> </ul>
5	dP-P&O	<ul style="list-style-type: none"> <li>Overcomes the drawback of traditional hill climbing method by preventing itself from being track in the undesirable direction.</li> <li>An additional power measurement in between two different sampling instances.</li> </ul>
6	Open circuit and Slope detection tracking	<ul style="list-style-type: none"> <li>Avoid unnecessary power loss as disconnection between solar panel and power stage occur only once and hence power efficiency is maintained.</li> <li>High tracking speed and accuracy.</li> </ul>

IV. PV SYSTEM

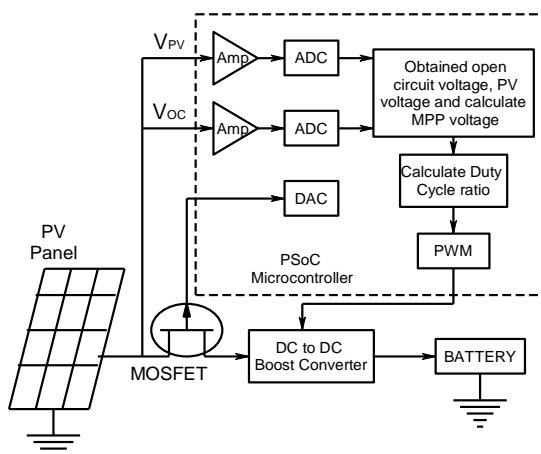

Fig.3. Block diagram of PV System. [3]

Photovoltaic (PV) is the field of technology related to the application of solar cells for energy by converting sunlight directly into electricity. Fig.3 shows the development of PV system as it composed of different parts like PV panel, charge storage device in the form of battery, DC to DC boost converter and controlling part. The smallest part of a PV panel is called photovoltaic cell. The electric energy from the solar cells is stored in the battery for immediate or later use. A Programmable System on Chip (PSoc) is used as an intelligent controller whose major role is to regulate the voltage and current from the solar cells before it is stored in the battery. It monitors the condition of the battery state of charge and protects the battery from being over charged. The charge controller also protect the battery from discharging below its lowest acceptable voltage.

V. CONCLUSION

This paper presents an overview of the Maximum Power Point Tracking methods and their difficulty of tracking, in the fast changing environmental conditions. Both of the most popular MPP trackers, the P&O and the INC possibly provide the tracking in improper direction during rapidly changing environmental conditions. This is mainly because of their inability to distinguish the result of their own perturbations from the environmental changes. A simple and effective

technique, which can overcome the drawback of above methods, has been reviewed called open circuit and slope detection tracking for fast changing environmental condition. The method separates the MPPT effects from environmental changes and provides correct information to the tracker, which is therefore not influenced by the environmental changes.

REFERENCES

- C.Y. Yang, "Highly efficient Analog Maximum Power Point Tracking (AMPPT) in a Photovoltaic System," *IEEE Trans. On Circuits and Systems-I*: vol. 59, 2012, pp. 1546–1556.
- R.A. Shayani, Senior Member IEEE, "Photovoltaic Generation Penetration Limits in Radial Distribution Systems," *IEEE Trans. On Power Systems*, Vol. 26, 2011, pp. 1625–1631.
- R. Namba, "Development of PSoc Microcontroller Based Solar Energy Storage System," *SICE Annual Conf. 2011*, Waseda University, Tokyo, Japan, 2011, pp. 718–721.
- D. Sera, "Improved MPPT method for rapidly changing environmental conditions," *IEEE Trans. On Industrial Electronics*, Institute of Energy Technology, Aalborg, Denmark, 2006, pp.1420–1425.
- F. Iov, "Power Electronics and Control of Renewable Energy Systems," *IEEE Trans. On Industrial Electronics*, Vol. 55, 2007, pp.1–27.
- R. Mastromauro, "Control Issues in Single Stage Photovoltaic Systems: MPPT, Current and Voltage Control," *IEEE Trans. On Industrial Informatics*, Vol. 8, 2012, pp.241–254.
- D. Sera, "Optimized Maximum Power Point Tracker for Fast-Changing Environmental Conditions," *IEEE Trans. On Industrial Electronics*, Vol. 55, 2008, pp. 2629–2637.
- A. Ponniran, "A Design of Low Power Single Axis Solar Tracking System Regardless of Motor Speed," *International Journal of Integrated Engineering*, Vol. 3, 2011, pp.5–9.
- W. Xiao, "Real-Time Identification of Optimal Operating Points in Photovoltaic Power Systems," *IEEE Trans. On Industrial Electronics*, Vol. 53, 2006, pp.1017–1026.

AUTHORS PROFILE



**Pawan D. Kale** received the B.E. degree in Electronics and Telecommunication Engineering from the, Amravati University in 2010, and he is currently pursuing the M. Tech. degree in Electronic System and Communication (ESC) at Government College of Engineering, Amravati.





**Dr. Devendra S. Chaudhari** obtained BE, ME, from Marathwada University, Aurangabad and PhD from Indian Institute of Technology, Bombay, Mumbai. He has been engaged in teaching, research for period of about 25 years and worked on DST-SERC sponsored Fast Track Project for Young Scientists. He has worked as Head Electronics and Telecommunication, Instrumentation, Electrical, Research and

incharge Principal at Government Engineering Colleges. Presently he is working as Head, Department of Electronics and Telecommunication Engineering at Government College of Engineering, Amravati. Dr. Chaudhari published research papers and presented papers in international conferences abroad at Seattle, USA and Austria, Europe. He worked as Chairman / Expert Member on different committees of All India Council for Technical Education, Directorate of Technical Education for Approval, Graduation, Inspection, Variation of Intake of diploma and degree Engineering Institutions. As a university recognized PhD research supervisor in Electronics and Computer Science Engineering he has been supervising research work since 2001. One research scholar received PhD under his supervision. He has worked as Chairman / Member on different university and college level committees like Examination, Academic, Senate, Board of Studies, etc. he chaired one of the Technical sessions of International Conference held at Nagpur. He is fellow of IE, IETE and life member of ISTE, BMESI and member of IEEE (2007). He is recipient of Best Engineering College Teacher Award of ISTE, New Delhi, Gold Medal Award of IETE, New Delhi, Engineering Achievement Award of IE (I), Nashik. He has organized various Continuing Education Programmes and delivered Expert Lectures on research at different places. He has also worked as ISTE Visiting Professor and visiting faculty member at Asian Institute of Technology, Bangkok, Thailand. His present research and teaching interests are in the field of Biomedical Engineering, Digital Signal Processing and Analogue Integrated Circuits.